

# DIMENSIONI D'INGOMBRO - OVERALL DIMENSIONS

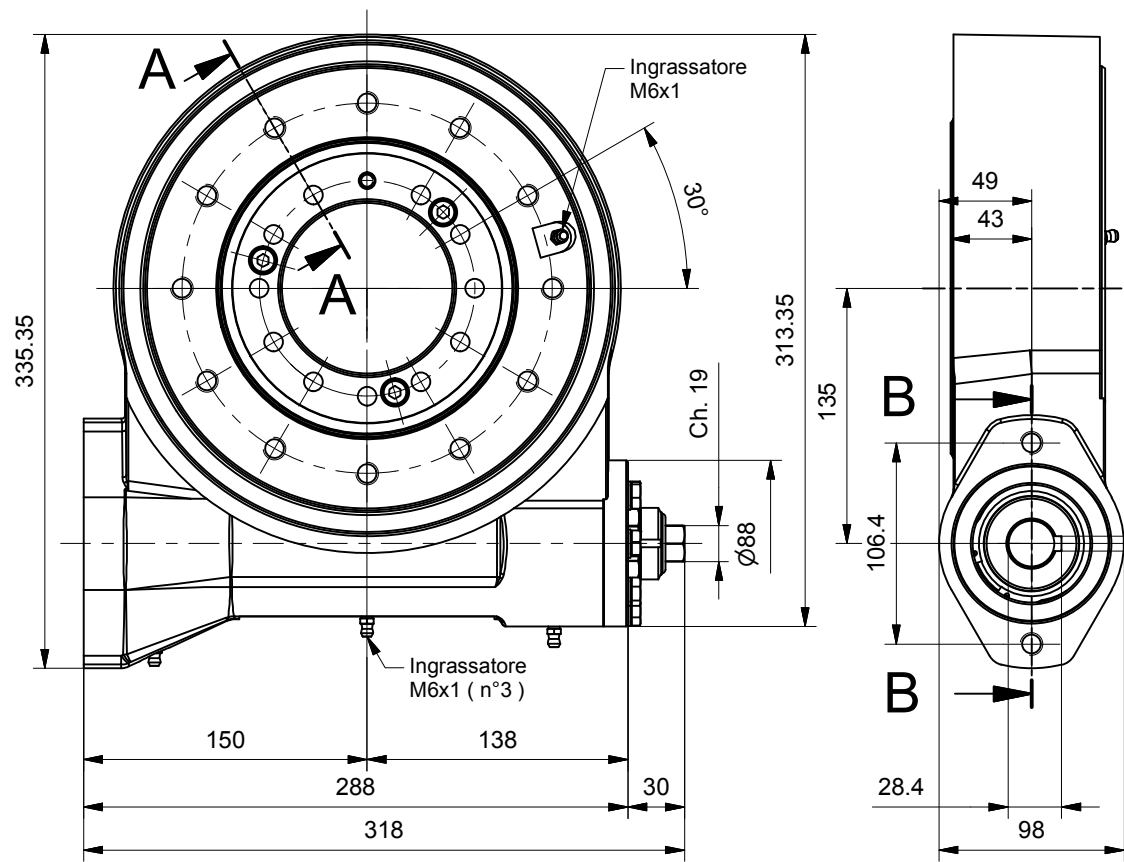

# DATI TECNICI - TECHNICAL DATA

Rapporto di riduzione  
Gear ratio  $r = 1 : 46$

Giri max. ingresso  
Max. input rpm  $n = 200$  rpm

Coppia max. uscita  
Max. output torque  $M_u = 2520$  Nm  
 { serv. continuo  
 continuous  
 di picco  
 peak

Coppia max. uscita in stallo ( C.frenante )  
Max stall output torque ( Braking torque )  $M_p = 3280$  Nm

Non è garantita la irreversibilità del moto  
Total nonreversing is not guaranteed  $M_r = 3280$  Nm

Peso  
Weight  $kg\ 30$

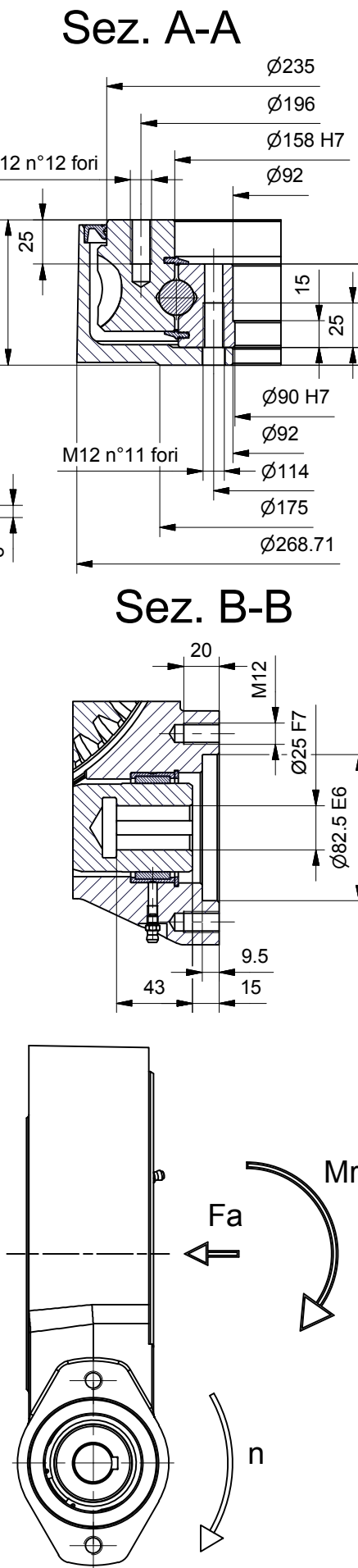

# DIAGRAMMI DEI CARICHI - LOADS DIAGRAMS

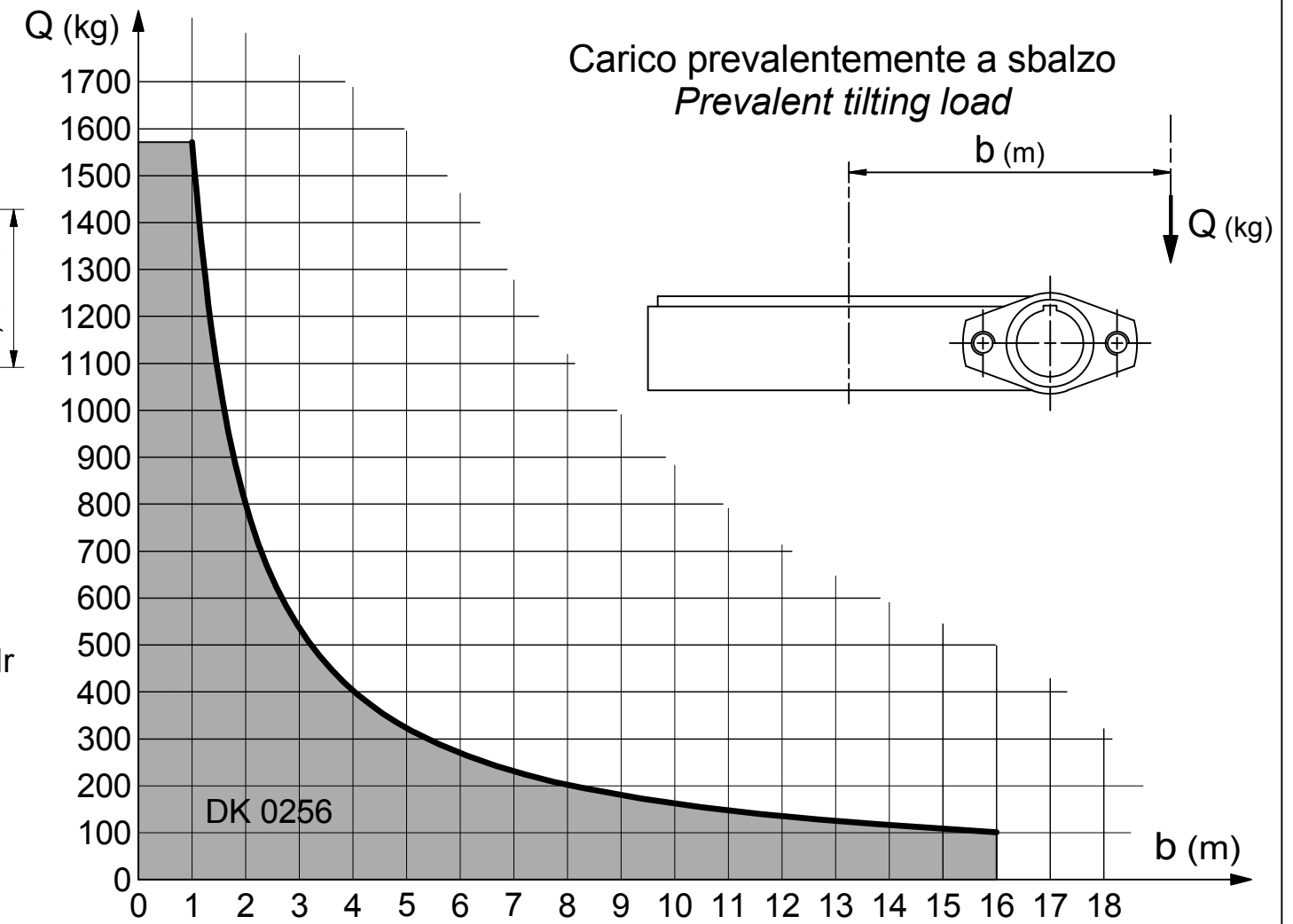
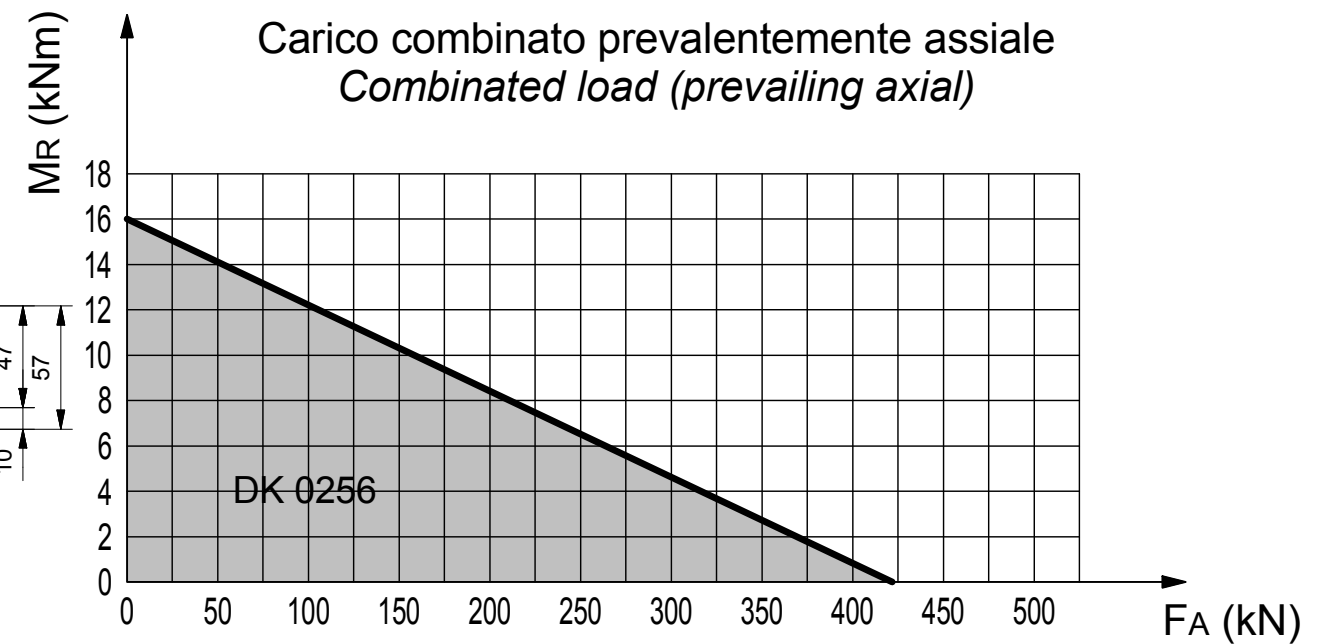

**Meta**  
HYDRAULIC

42048 RUBIERA (RE) ITALY

SCHEDA TECNICA - TECHNICAL SHEET  
GRUPPO RALLA DI ROTAZIONE - SLEWING RING  
DK0256

COD. GRXDK02560 REV. 00